

STANDARD SILLS

LENGTH OF EACH SEGMENT IS 86"
SIZES SHOWN MAY HAVE A VARIANCE OF
UP TO 1/4" DEPENDING ON COATING/
FINISHING TYPE

SS-101

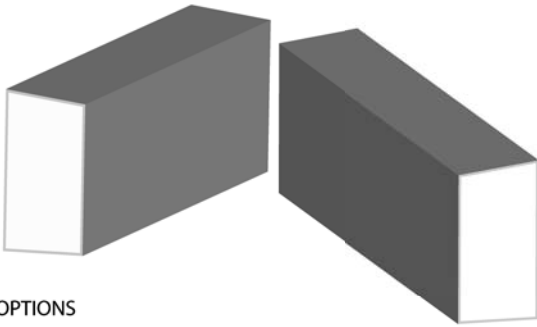
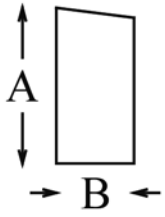

SIZE OPTIONS

- | | |
|------------------|------------------|
| 1. A=5" B=2-1/2" | 4. A=8" B=4-0" |
| 2. A=6" B=3-0" | 5. A=9" B=4-1/2" |
| 3. A=7" B=3-1/2" | 6. A=10" B=5-0" |



SS-102

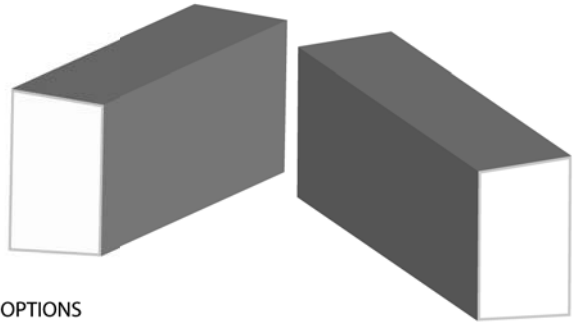
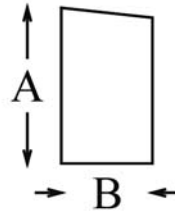

SIZE OPTIONS

- | | |
|------------------|-------------------|
| 1. A=5" B=2-7/8" | 4. A=8" B=4-5/8" |
| 2. A=6" B=3-1/2" | 5. A=9" B=5-1/4" |
| 3. A=7" B=4-1/8" | 6. A=10" B=5-7/8" |



SS-103

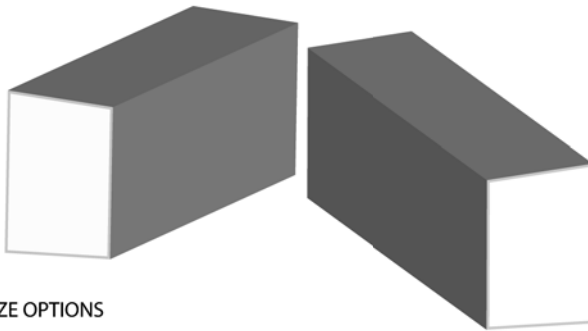

SIZE OPTIONS

- | | |
|------------------|-------------------|
| 1. A=5" B=3-7/8" | 4. A=8" B=5-3/8" |
| 2. A=6" B=4-0" | 5. A=9" B=6-0" |
| 3. A=7" B=4-5/8" | 6. A=10" B=6-5/8" |



SS-104

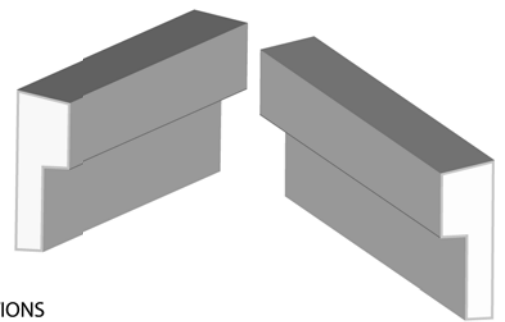
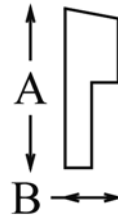

SIZE OPTIONS

- | | |
|------------------|-------------------|
| 1. A=5" B=1-5/8" | 4. A=8" B=2-5/8" |
| 2. A=6" B=2-0" | 5. A=9" B=3-0" |
| 3. A=7" B=2-3/8" | 6. A=10" B=3-3/8" |



SS-105

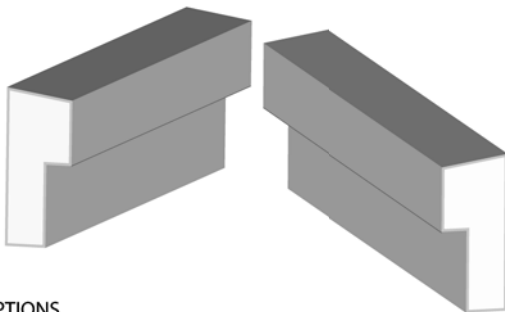
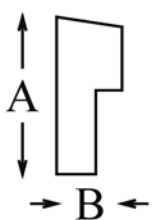

SIZE OPTIONS

- | | |
|------------------|-------------------|
| 1. A=5" B=2-1/8" | 4. A=8" B=3-3/8" |
| 2. A=6" B=2-1/2" | 5. A=9" B=3-3/4" |
| 3. A=7" B=2-7/8" | 6. A=10" B=4-1/8" |



SS-106

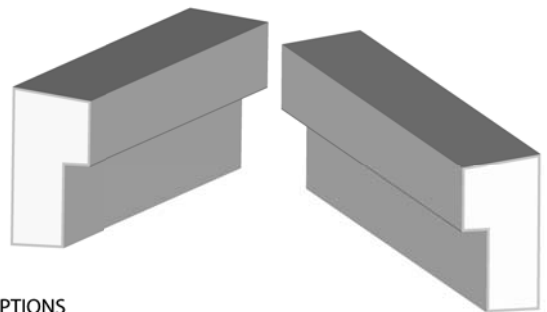
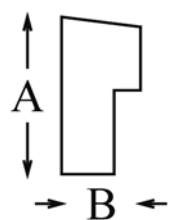

SIZE OPTIONS

- | | |
|------------------|------------------|
| 1. A=5" B=2-1/2" | 4. A=8" B=4-0" |
| 2. A=6" B=3-0" | 5. A=9" B=4-1/2" |
| 3. A=7" B=3-1/2" | 6. A=10" B=5-0" |



SS-107

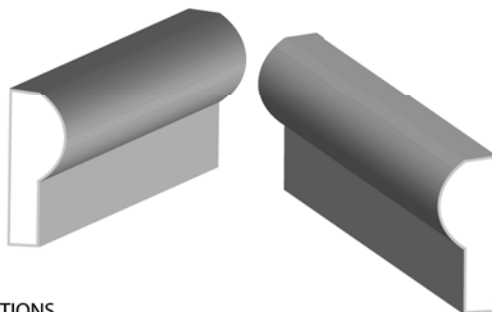

SIZE OPTIONS

- | | |
|------------------|-------------------|
| 1. A=5" B=1-7/8" | 4. A=8" B=3-0" |
| 2. A=6" B=2-1/4" | 5. A=9" B=3-3/8" |
| 3. A=7" B=2-5/8" | 6. A=10" B=3-3/4" |



SS-108

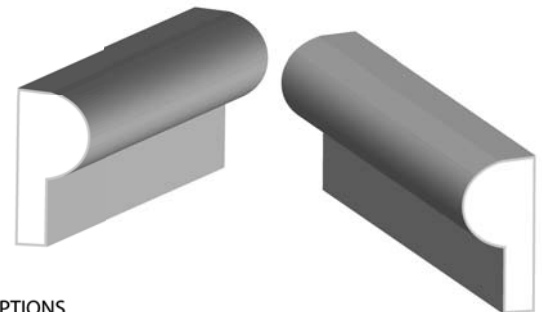
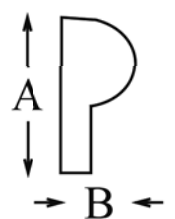

SIZE OPTIONS

- | | |
|------------------|-------------------|
| 1. A=5" B=2-3/8" | 4. A=8" B=3-7/8" |
| 2. A=6" B=2-7/8" | 5. A=9" B=4-3/8" |
| 3. A=7" B=3-3/8" | 6. A=10" B=4-3/4" |

